



ITC等温滴定微量热技术培训

欧惠超

ohc@ustc.edu.cn

中国科学技术大学生命科学实验中心

<http://lifetech.ustc.edu.cn>





中心现有ITC仪器

4台仪器均可用

PEAQ-ITC

2024年

功能完整



ITC200

2019年

样品池 外置泵清洗



ITC200

2011年

13年，外置泵清洗



VP-ITC

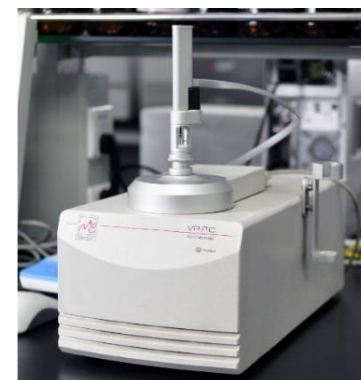

2007年

17年，功能完整





各型号对比

仪器	噪音	样品需求量	优点
	PEAQ-ITC 0.15 ncal/s	滴定针60 μ L 样品池280 μ L	省时省样品 实验操作和数据分析更简单
	ITC200 0.2 ncal/s	*滴定针容量40 μ L 样品池容量200 μ L	省时省样品 机时费更低
	VP-ITC 0.2 ncal/s	滴定针0.5mL 样品池2mL *滴定针和样品池容量均大7倍	信噪比更好 能测出更微弱的相互作用热量





ITC什么原理？能做什么？





ITC基本原理

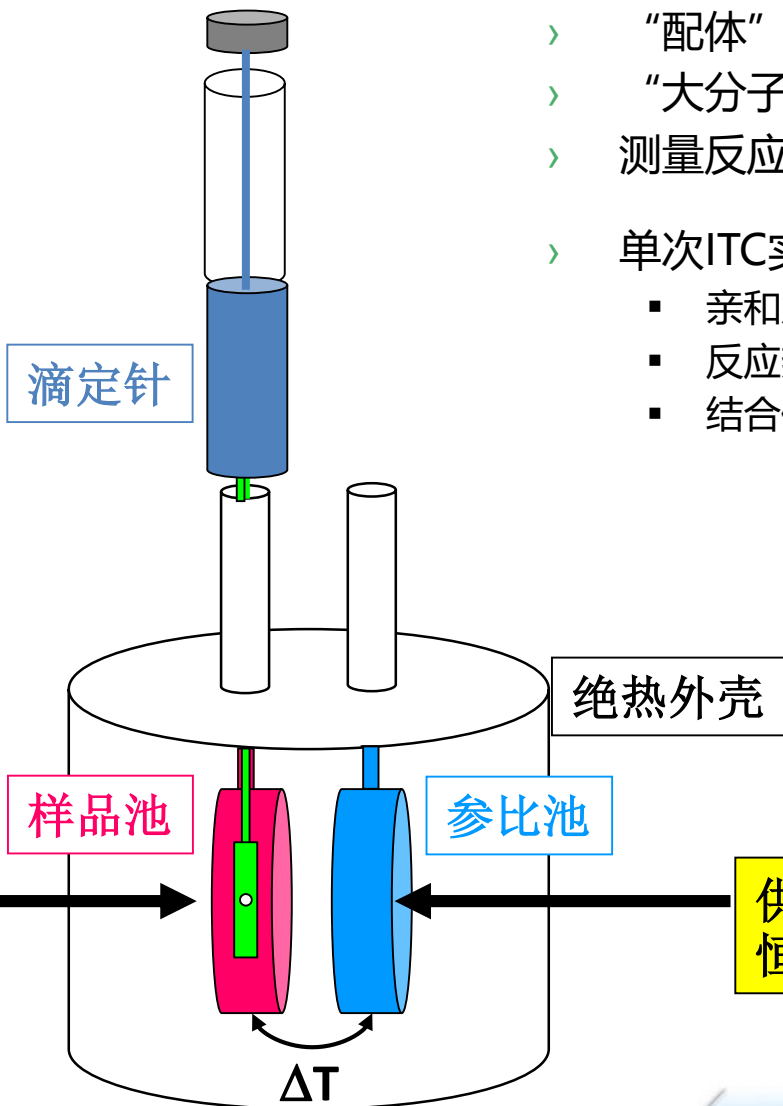
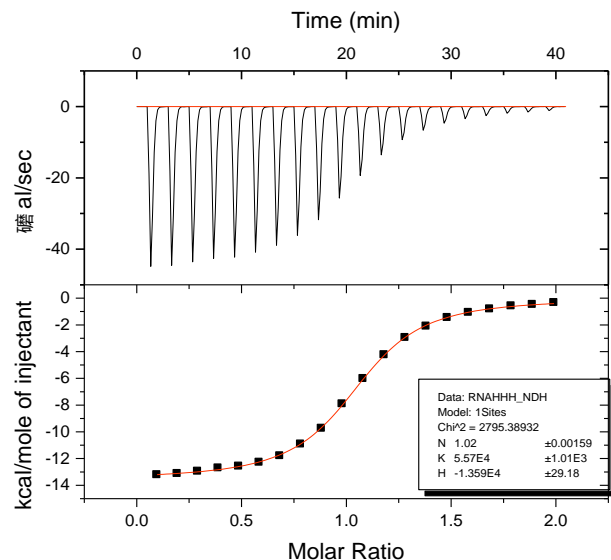

- › “配体” 放在滴定针中
- › “大分子” 放在样品池
- › 测量反应热
- › 单次ITC实验可获得的参数：
 - 亲和力 (K_D)
 - 反应热 (ΔH)
 - 结合位点的数目 (N)

数据输出

根据 ΔT 调节供给样品池的能量

绝热外壳

样品池

参比池

供给参比池恒定的能量

ΔT





ITC基本原理

基于热量检测的通用技术

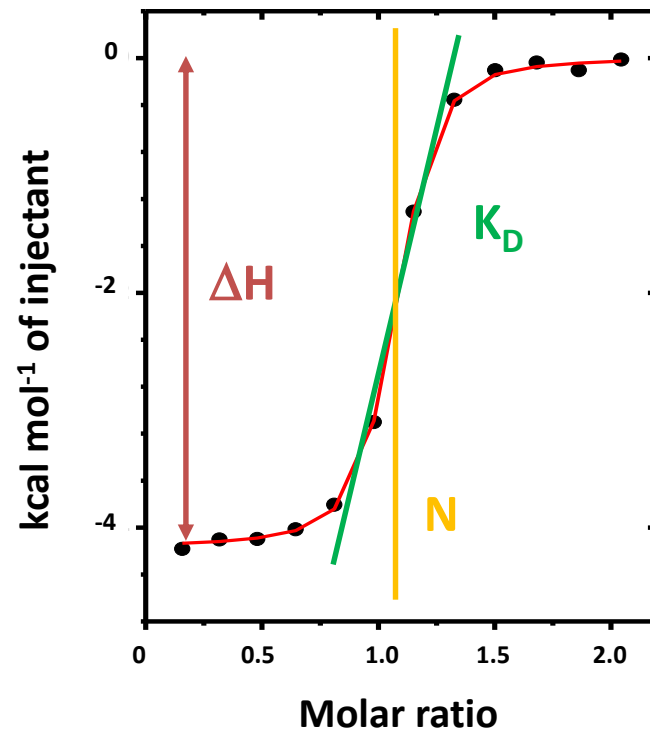
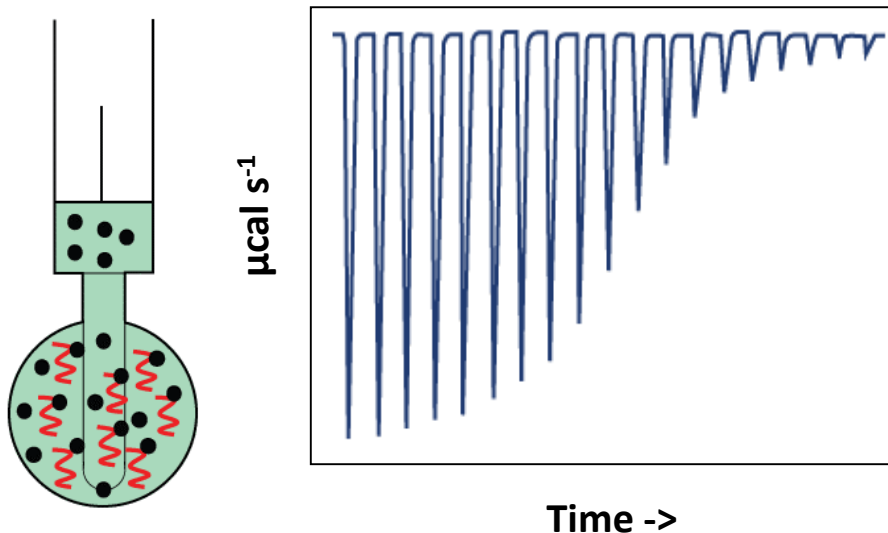

1. 原始数据积分;
2. 将热量进行积分并运用合适的结合模型得到: 亲和力 (K_D), 化学计量比 (N) 和反应焓变(ΔH);
3. 通过热力学公式, 计算得到反应熵变(ΔS)。

K_D : Affinity
 N : Stoichiometry
 ΔH : Enthalpy
 ΔS : Entropy

$$\Delta G = RT \ln K_D = \Delta H - T\Delta S$$



特点

- ✓ 通用的检测器
- ✓ 简单的分析设计
- ✓ 很容易操作
- ✓ **分子量范围广**
- ✓ **溶液中检测**
- ✓ **无需标记**
- ✓ 非光学检测

应用

- 任意两种分子间的相互作用
 - 证实结合以及活性
 - 获得亲和力、结合比和热力学参数
- 研究相互作用机制
- 药物研发
 - 用热力学指导先导化合物的优化
 - 确认IC50和EC50
- 酶动力学



ITC – protein small molecule interaction

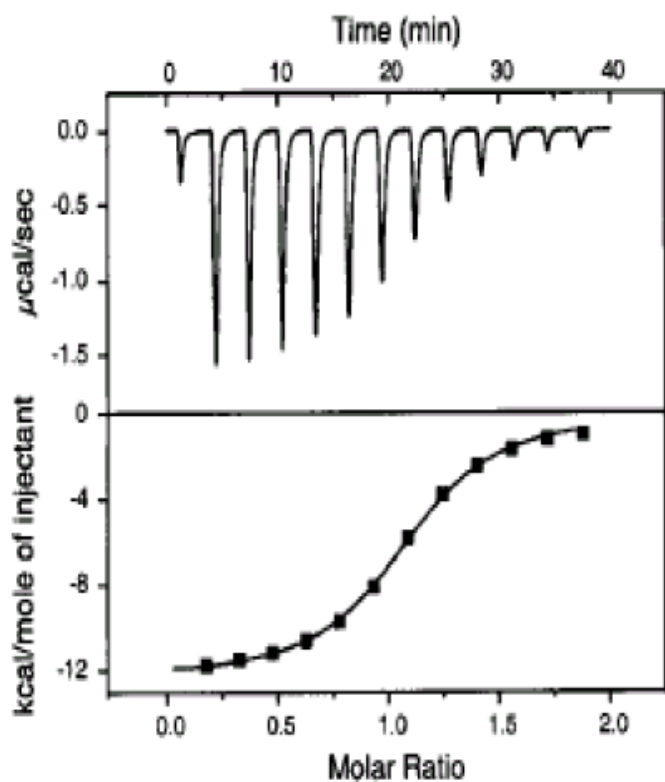

4-carboxybenzene-sulfonamide
titrated into carbonic anhydrase II

$$N = 0.97$$

$$K_D = 730 \text{ nM}$$

$$\Delta H = -11.9 \text{ kcal/mol}$$



Protein-protein interactions

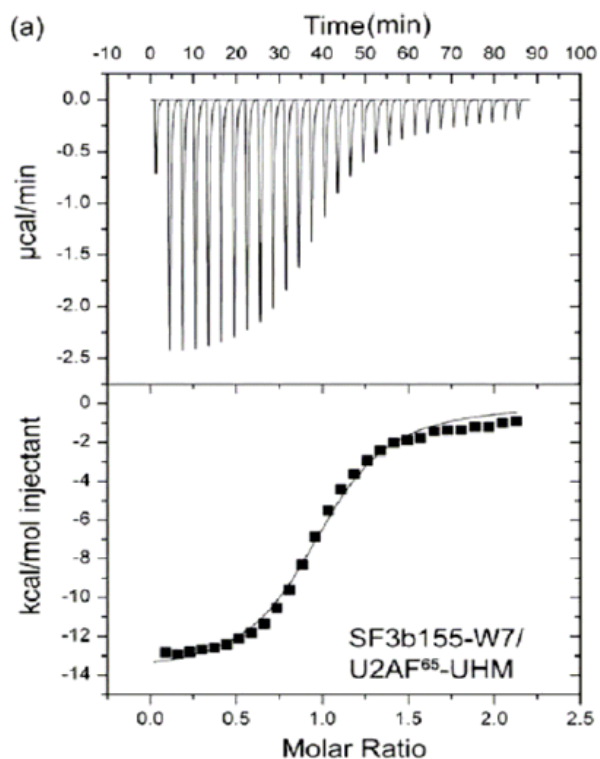

C-terminal domain of nuclear RNA auxiliary factor (U2AF⁶⁵-UHM) binding to spliceosomal component mutant SF3b155-W7 (shown) or wild-type SF3b155

	SF3b155-W7	Wild-type SF3b155
K_D (μM)	2.50	2.83
ΔG (kcal/mol)	-7.8	-7.7
ΔH (kcal/mol)	-14.9	-9.4
ΔS (cal/mole/ $^\circ\text{K}$)	-23.4	-5.6

ΔH : 焓变, 当 $\Delta H < 0$ 时表示反应由焓驱动, 通常是通过**氢键**、**离子键**、**范德华力**产生相互作用;

ΔS : 熵变, $-T \Delta S < 0$ 表示是熵驱动的过程, 通常是发生了**疏水相互作用**, 或产生了**构象变化**等。





Multiple binding sites

ITC shows differential binding of Mn(II) ions to WT T5 5' nuclease

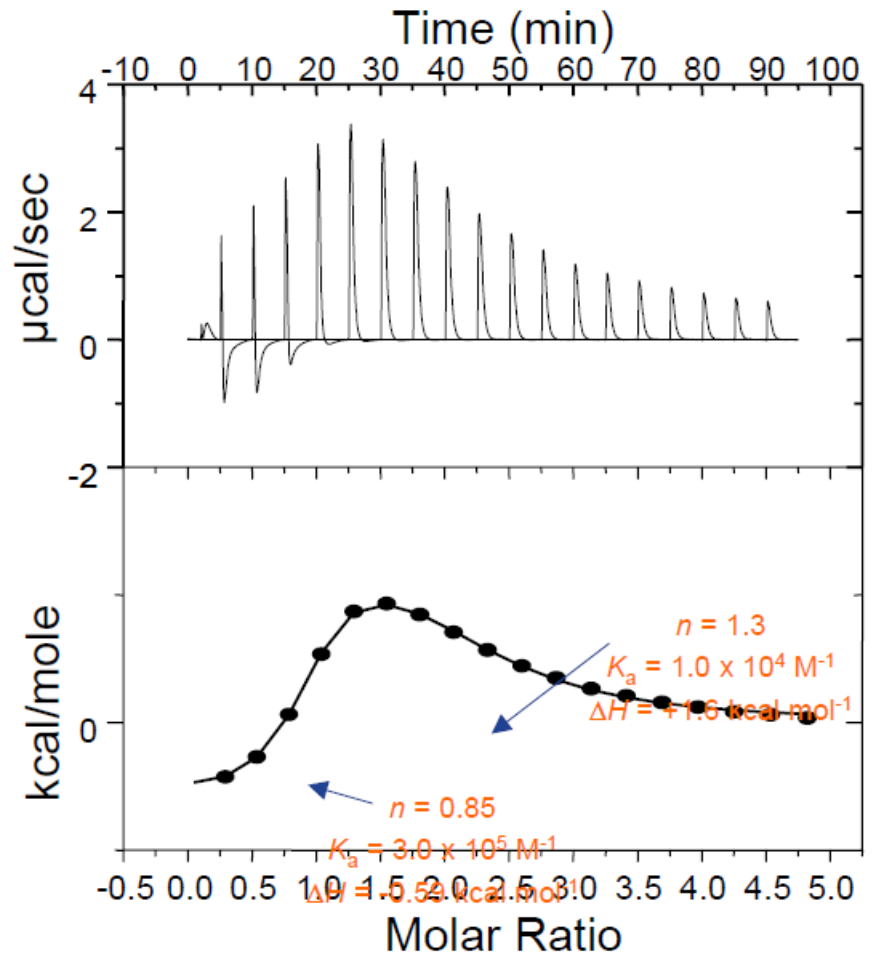
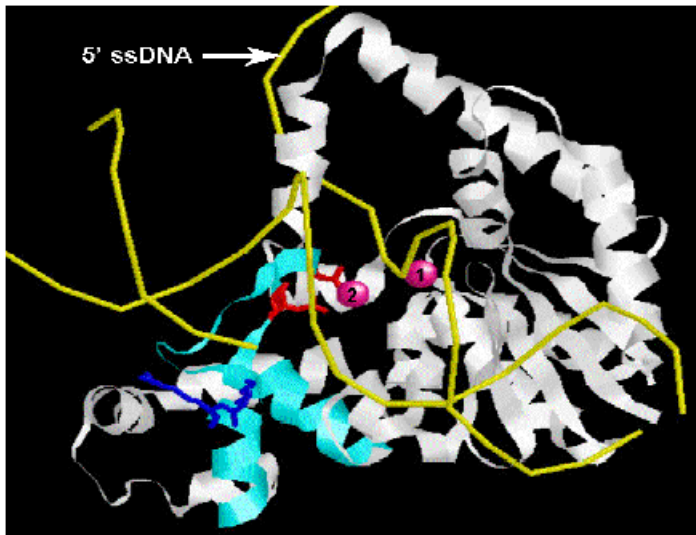



ITC实验怎么做?

(以PEAQ-ITC为例)





基本实验流程

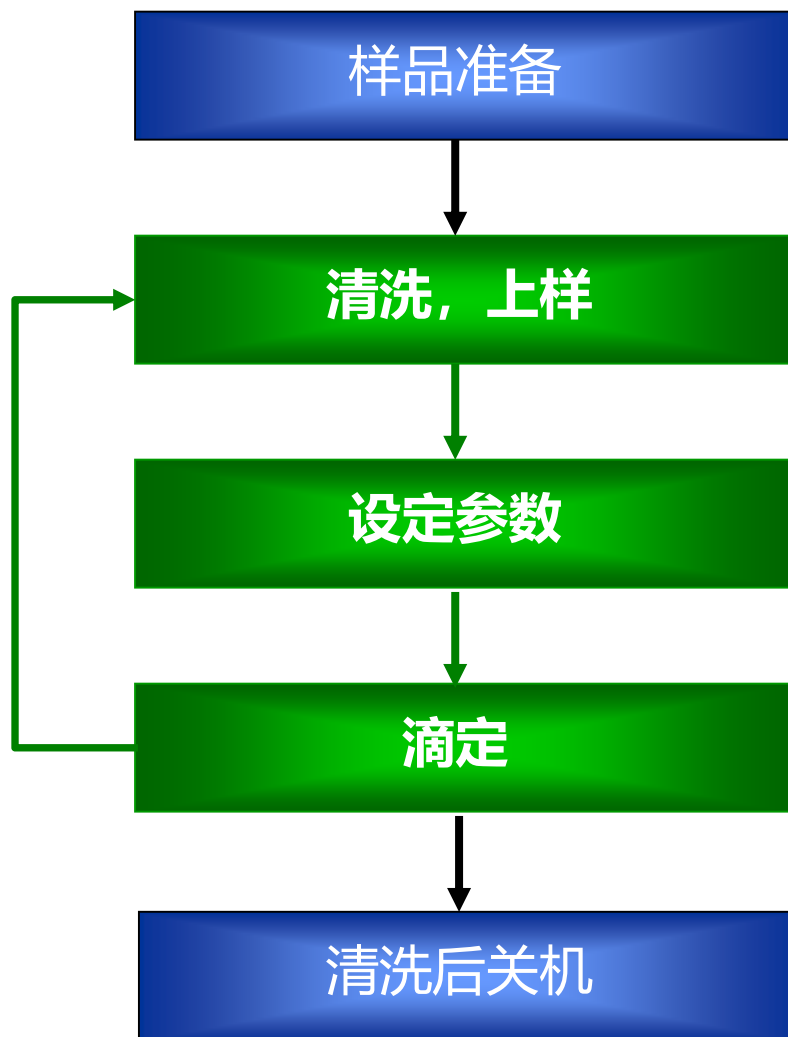

样品准备-浓度与体积

➤ 样品浓度:

如果已知KD值, 可根据公式估算 (样品池样品浓度= $C \cdot K_D \cdot N$, C值一般在10-100之间实验结果最好)

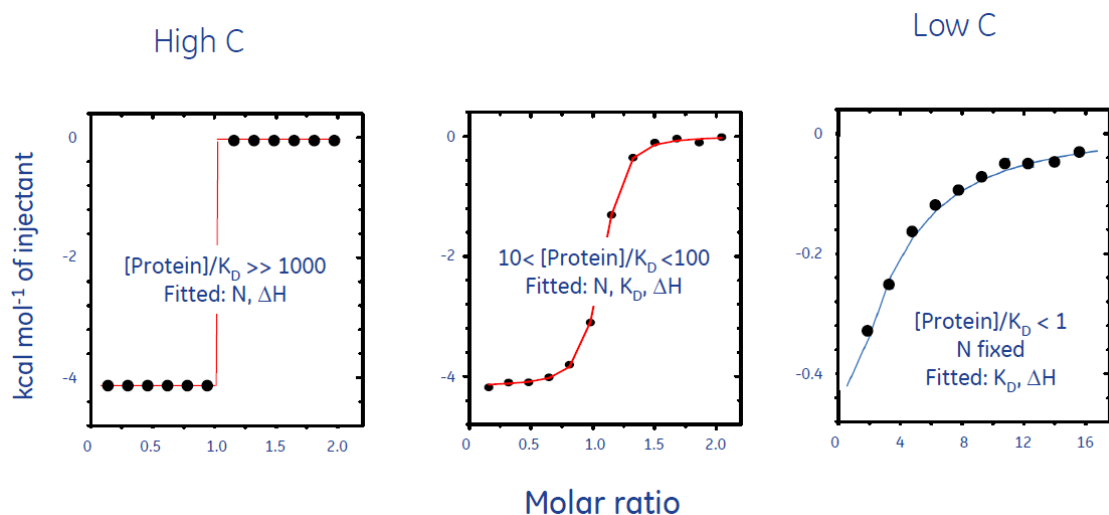

如果不清楚KD, 可按经验浓度范围进行准备, 样品池一般为10uM~10mM, 滴定针比样品池浓度一般高10-20倍, 建议初始尝试200uM滴20uM

➤ **样品体积:** 样品池280ul (建议350-400), 滴定针60ul (建议100)

➤ 一个ITC实验一般包含A to B 和 A to Buffer两次滴定, A需要双用量。





样品准备-前处理

➤ 样品要求:

样品要澄清无颗粒，可通过离心或微滤处理

两个样品所用缓冲液尽可能完全一致，pH差值 < 0.05

缓冲液交换和脱盐：透析、凝胶过滤、超滤、渗滤、沉淀析出和固相萃取。
尽可能避免使用有机溶剂！

如需使用还原剂，最好使用：

TCEP (Tris (2-carboxyethylphosphine) hydrochloride, $\leq 2\text{mM}$)

β - 巯基乙醇 (β -mercaptoethanol, β -ME, $\leq 5\text{mM}$)

避免使用DTT (自身氧化放热，导致背景漂移)

➤ 真空脱气5min (推荐) 或离心脱气10min (12000rpm或以上)

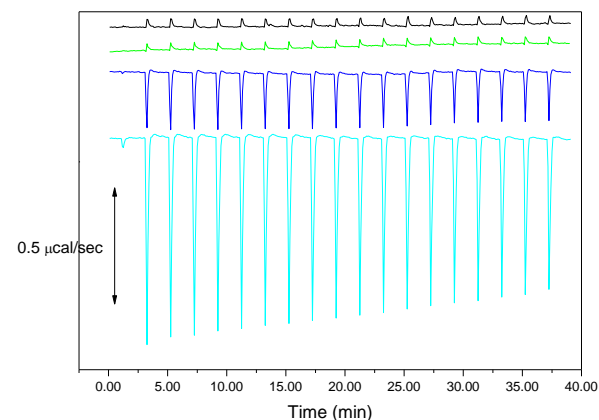
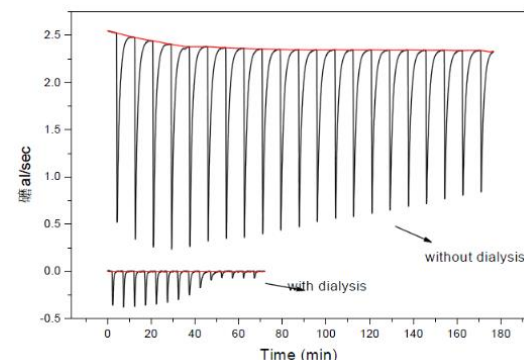

检查溶液瓶-刷卡开机

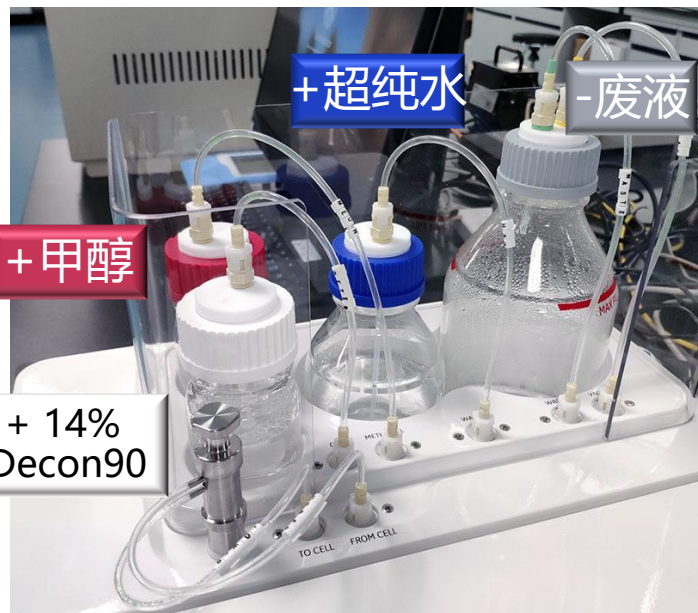

2个电源指示灯亮起

联机

- 打开控制软件 (ITC 图标), 注意查看联机状态Online/Offline

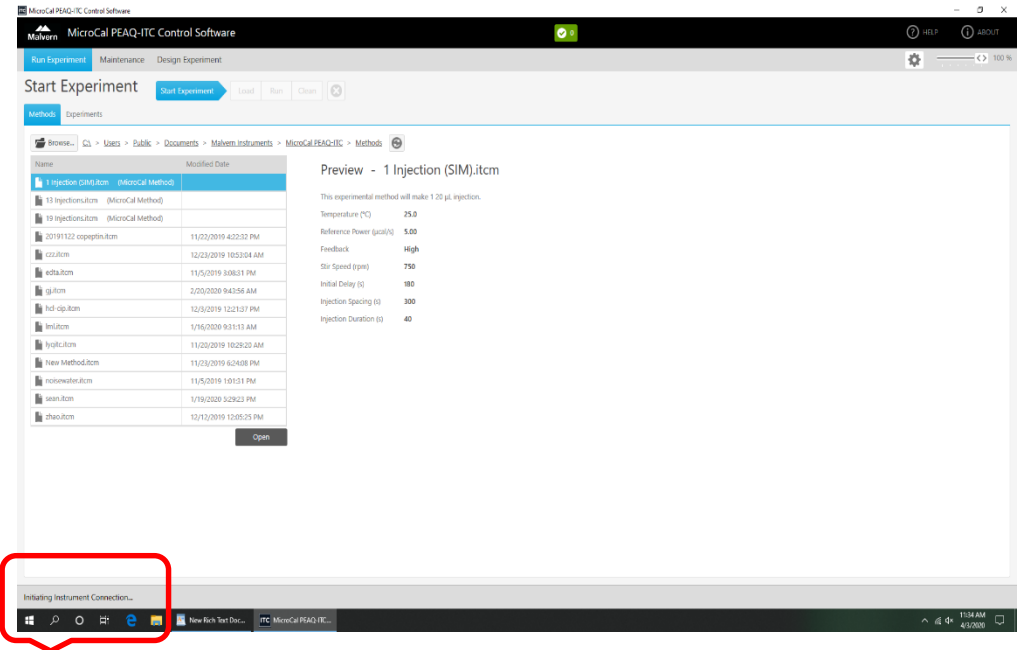
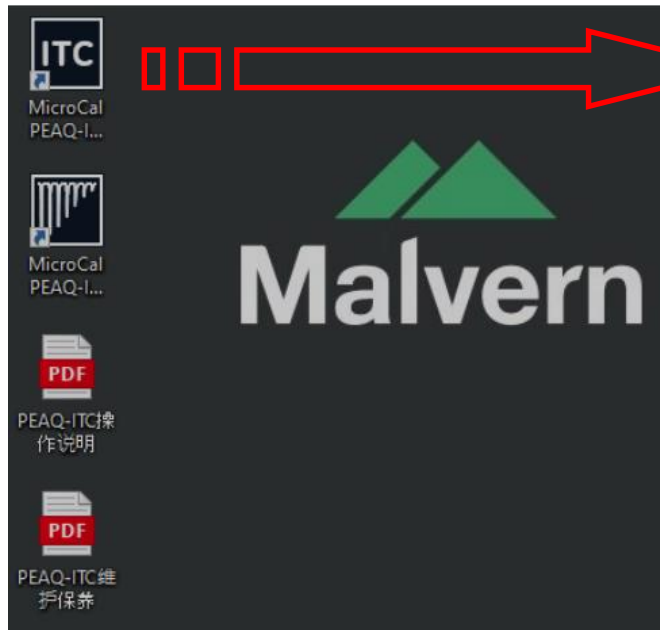

Initiating Instrument Connection...



控制软件——首标

提示消息

About

MicroCal PEAQ-ITC Control Software

Malvern MicroCal PEAQ-ITC Control Software

Run Experiment Maintenance Design Experiment

Start Experiment Start Experiment Load Run Clean

Methods Experiments

Browse... C:\ > Users > Public > Documents > Malvern Instruments > MicroCal PEAQ-ITC > Methods

Name	Modified Date
13 Injections.itcm (MicroCal Method)	
19 Injections.itcm (MicroCal Method)	

Open

Preview - 13 Injections.itcm

This experimental method will make a single 0.4 μL injection, followed by 12, 3 μL injections.

Temperature ($^{\circ}\text{C}$)	25.0
Reference Power (μW)	41.9
Feedback	High
Stir Speed (rpm)	750
Initial Delay (s)	60.0
Injection Spacing (s)	150
Injection Duration (s)	6

Instrument Offline



控制软件——主导航栏

实验参数设置

实验设计

设置

The screenshot shows the MicroCal PEAQ-ITC Control Software interface. A red box highlights the main navigation bar at the top, which includes the following elements:

- Buttons: Run Experiment (highlighted), Maintenance, Design Experiment
- System icons: Malvern logo, a red warning icon with the number '2', and HELP/ABOUT links.
- Settings: A gear icon and a zoom control set to 100%.

Below the navigation bar, the interface is divided into several sections:

- Run Section:** Contains 'Start Experiment', 'Load', 'Run' (highlighted), and 'Clean' buttons.
- Experiment Parameters:** Includes fields for [Syr] (M), [Cell] (M) (set to 0), and a Comment text area.
- Instrument Settings:** A list of parameters including Temperature (°C) set to 25.0, Reference Power (10.0), Feedback (High), Stir Speed (750), Initial Delay (60), and Injection Spacing (150).
- Process Flow:** A horizontal timeline with four stages: Idle (active), Setting Temperature, Equilibrating, and Injecting (0/13).
- Graph:** A plot of DP (μcal/s) vs Time (min) with a y-axis from -0.04 to 0.04 and an x-axis from -0.4 to 0.5.
- Bottom Bar:** Shows 'Instrument Offline' and buttons for 'Start', 'Analyze', and 'Save As Method'.

Callouts with arrows point to specific features:

- '实验参数设置' points to the 'Run Experiment' button.
- '实验设计' points to the 'Design Experiment' button.
- '设置' points to the gear icon in the navigation bar.
- '仪器维护视频' points to the 'Start Experiment' button.
- '字体大小设置' points to the zoom control in the navigation bar.



控制软件——打开和编辑实验方法

Start Experiment

Methods

Name	Modified Date
13 Injections.itcm (MicroCal Method)	
19 Injections.itcm (MicroCal Method)	
guoyj.itcm	1/12/2016 3:51:33 PM
H2O.itcm	2/4/2016 10:27:36 AM
husc.itcm	2/17/2016 9:34:37 AM
noise.itcm	8/10/2015 12:05:13 AM
wychen.itcm	8/31/2015 9:34:04 PM
Min.Yang	11/23/2015 8:41:17 PM

Open

打开一个方法

Run

Experiment Information

[Syr] (M) 0 **样品浓度**

[Cell] (M) 0

Comment

修改实验参数

Instrument Settings

Temperature (°C) 25.0

This experimental method will make a single 0.4 μL injection, followed by 12, 3 μL injections.

The following settings will be used:

Reference Power ($\mu\text{cal/s}$)	10.0
Feedback	High
Stir Speed (rpm)	750
Initial Delay (s)	60
Injection Spacing (s)	150

参数编辑

Injection	Volume (μL)	Duration (s)	Spacing (s)
1	0.4	0.8	150
2	3.0	6.0	150
3	3.0	6.0	150
4	3.0	6.0	150
5	3.0	6.0	150
6	3.0	6.0	150
7	3.0	6.0	150
8	3.0	6.0	150

DP ($\mu\text{cal/s}$)

Graph showing DP ($\mu\text{cal/s}$) vs. Injection number.

Apply to All Apply to Rest

Idle

Stop Idle Temperature (°C): 25 Set Syringe: Load Plun

控制软件——清洗与上样操作视频

4003384toTD2-2.itc - MicroCal PEAQ-ITC Control Software

Malvern MicroCal PEAQ-ITC Control Software

Run Experiment Maintenance Design Experiment

Clean Start Experiment Load Run Clean

0 1 2 3 4 5 6

0 Introduction

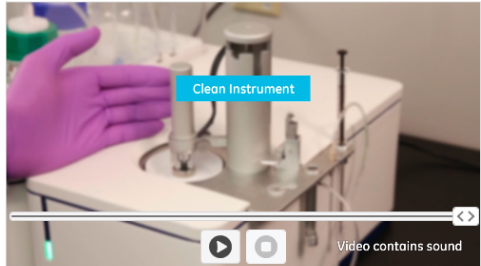
 To view a video depicting all the cleaning steps, click the Play button.
To enter the Clean Instrument workflow, click Next.

Back Next

- 1 Choose Cleaning Method(s)
- 2 Insert Cell Cleaning Tool
- 3 Attach Fill Port Adapter
- 4 Move Pipette to Clean Location
- 5 Detach Fill Port Adapter
- 6 Remove Cell Cleaning Tool

Show entire video in external player

Instrument Online DP (μcal/s): 4.95 Temperature (°C): 22.7

Stop Idle Temperature (°C): 25 Set Syringe: Load Plunger Down Cell Clean: None Syringe Clean: None Clean

Windows taskbar: ITC 4003384toTD2-2.itc ... Untitled* - Paint 3D 10:36 AM 4/5/2020



控制软件——仪器控制

MicroCal PEAQ-ITC Control Software

Run Experiment Maintenance Design Experiment

Run Start Experiment Load Run Clean

Experiment Information

[Syr] (M) 500e-6
[Cell] (M) 33.0e-6
Comment

Instrument Settings

Temperature (°C) 25.0

This experimental method will make a single 1 μ l injection, followed by 18, 2 μ l injections.

The following settings will be used:

Reference Power (μ cal/s) 5.00
Feedback High
Stir Speed (rpm) 750
Initial Delay (s) 60
Injection Spacing (s) 120
Injection Duration (s) 4.0

DP (μ cal/s)

Time (min)

③开始实验

分析数据

另存方法

实时DP值和温度

Start Analyze Save As Method

Instrument Online DP (μ cal/s): 4.96 Temperature (°C): 21.5

Stop Idle Temperature (°C): 25 Set Syringe: Load Plunger Down Cell Clean: None Syringe Clean: None Clean

手动停止实验

设置温度

②滴定针上样

①样品池/滴定针清洗





样品池清洗

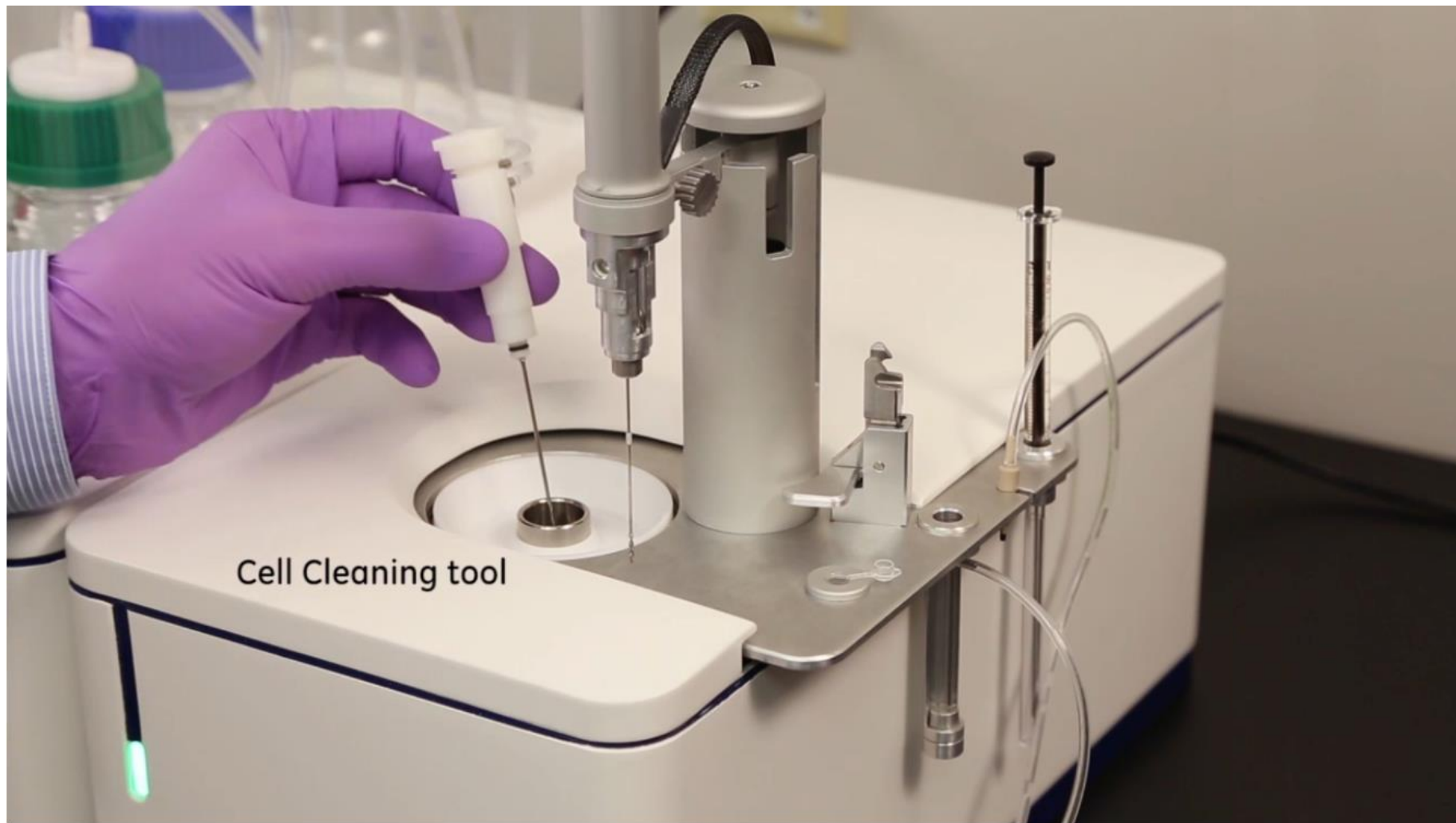

滴定针清洗-连接FPA



滴定针清洗-转入清洗孔





样品池上样

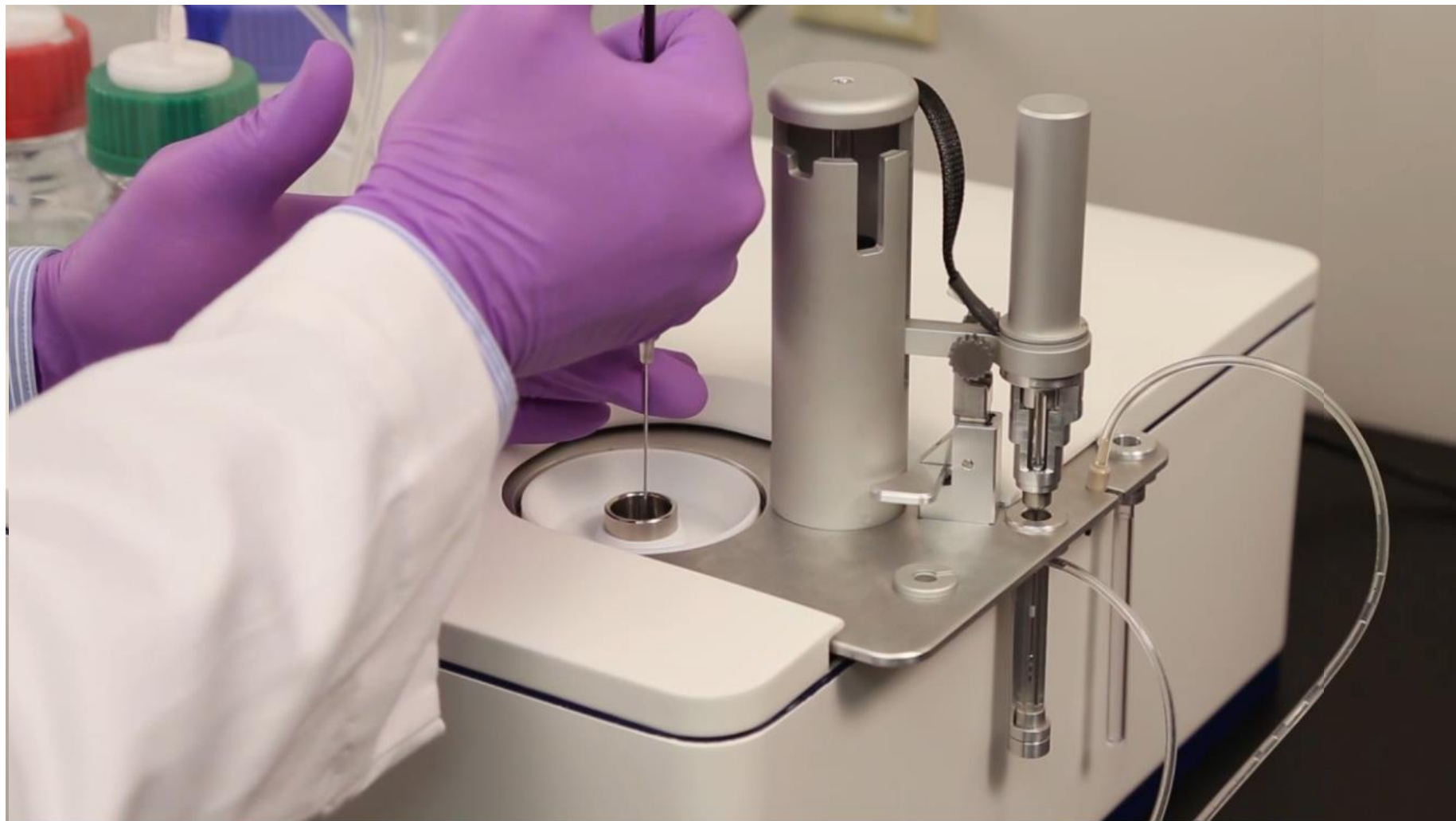



样品池上样

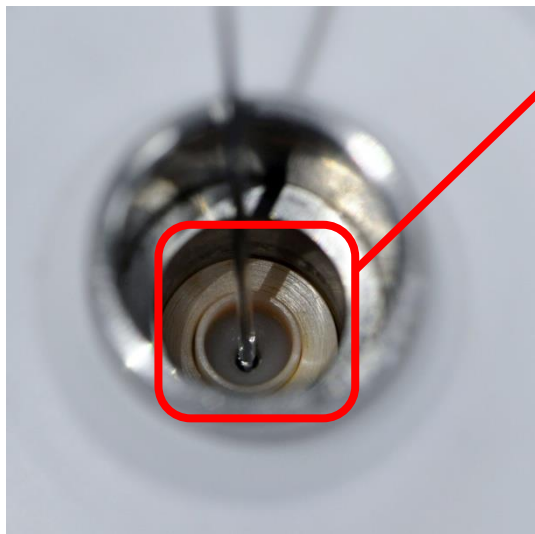

将注射器取出时，要保证样品池池口外还能看到溶液



将注射器卡在样品池池口，把池口外的溶液吸干

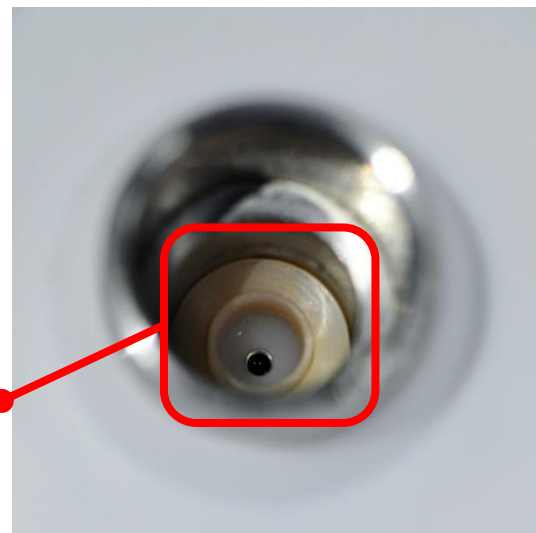



滴定针上样





滴定针上样

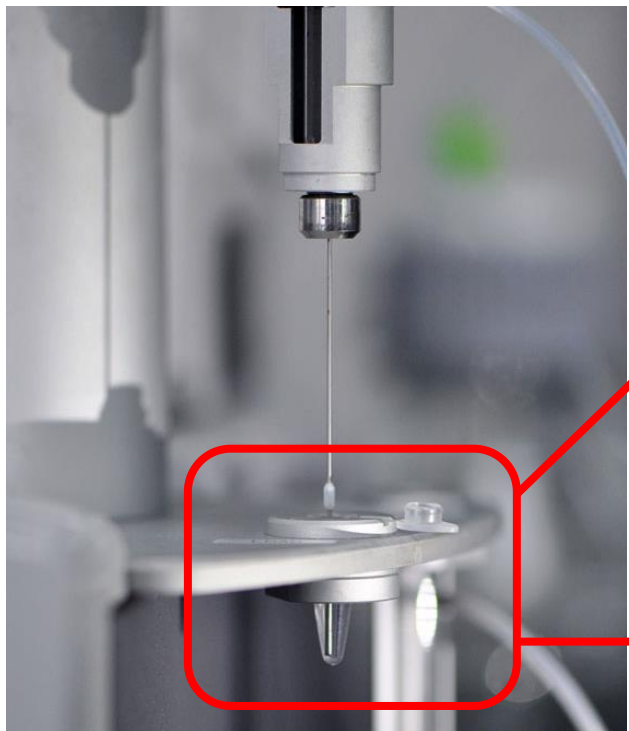

至少准备60ul
建议准备100ul +

不要触底，
稍留点空间

如残留气泡，直径小于
2-3mm不影响滴定

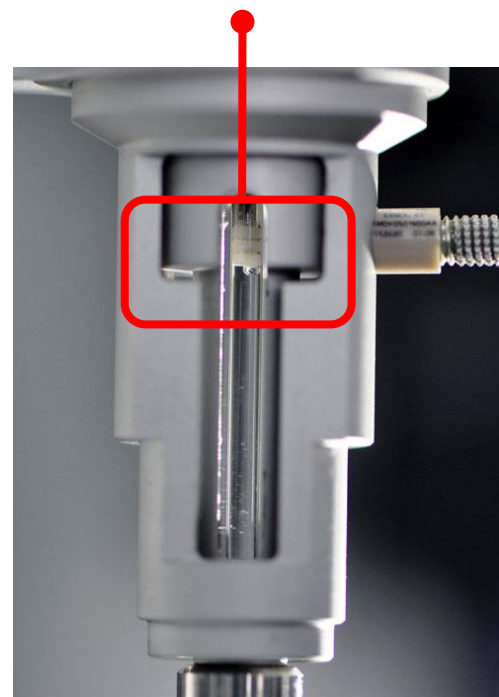

滴定针上样后-解除FPA



滴定针上样-转入样品池





实验全程，切勿碰到滴定针！以防折弯！！！！

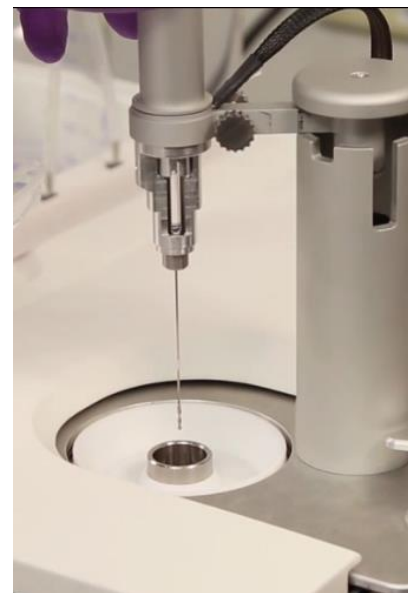
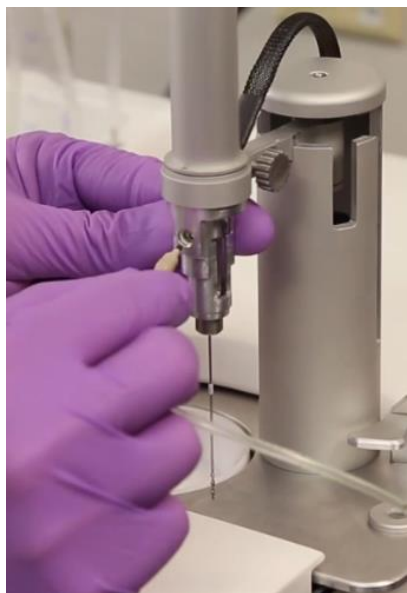

设定参数-开始滴定

New Experiment - MicroCal PEAQ-ITC Control Software

MicroCal PEAQ-ITC Control Software

Run Experiment Maintenance Design Experiment

Run Start Experiment Load Run Clean

Experiment Information

[Syr] (M) 0
[Cell] (M) 0
Comment

Instrument Settings

Temperature (°C) 25.0
Reference Power (μcal/s) 10.0
FeedBack High
Stir Speed (rpm) 750
Initial Delay (s) 60

Injection Settings

of Injections 13

Injection	Volume (μL)	Duration (s)	Spacing (s)
1	0.4	0.8	150
2	3.0	6.0	150
3	3.0	6.0	150
4	3.0	6.0	150
5	3.0	6.0	150
6	3.0	6.0	150
7	3.0	6.0	150
8	3.0	6.0	150

DP (μcal/s)

0.05
0.04
0.03
0.02
0.01
0
-0.01
-0.02
-0.03
-0.04
-0.05

Idle Setting Temperature Equilibrating Injecting (0/13) Ready

开始滴定

Start Analyze Save As Method

Idle

Stop Idle Temperature (°C): 25 Set Syringe: Load Plunger Down Open Fill Port Close Fill Port Purge/Refill Cell Clean: Wash Syringe

范围是2-80
一般是5或者10
默认转速750
一般是60-120
一般是2ul/滴, 不大于3ul/滴
第一滴体积可以改小

一般为90-180



实验结束-清洗后关机

- 清洗样品池和滴定针，清空废液瓶
- 松开卡扣，仪器关机，刷卡
- 数据处理

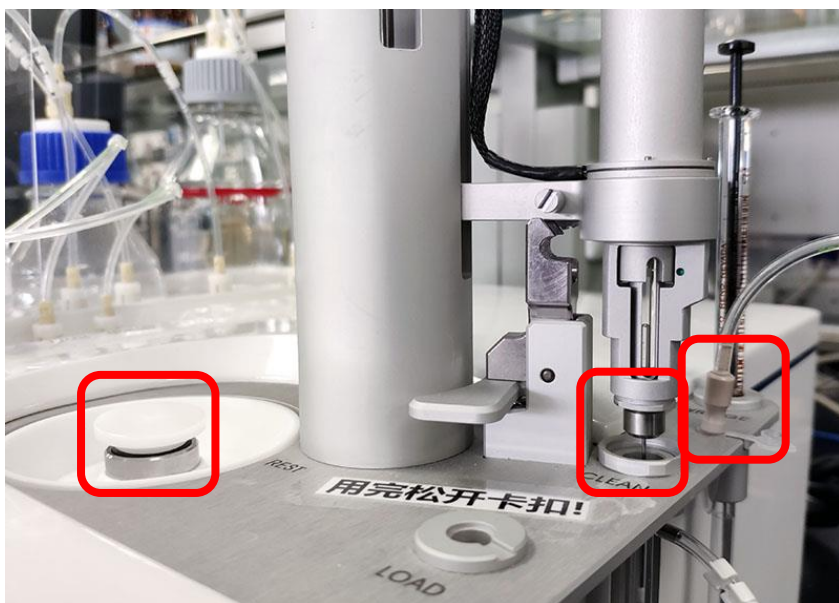
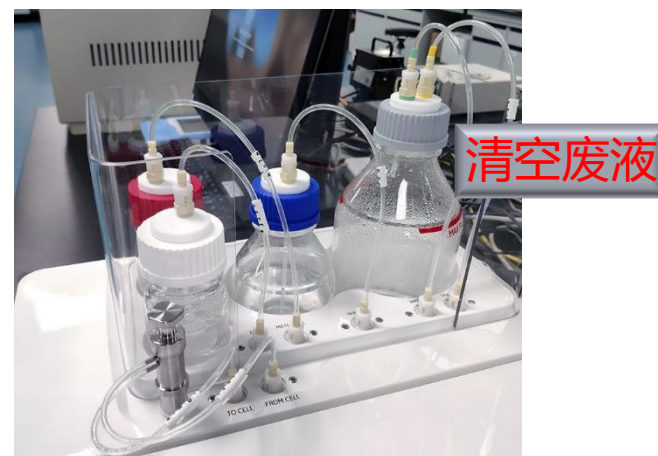



样品池与参比池

每天实验前，先做**水滴水**，确认**仪器状态和洁净度OK**

平衡时，DP值= “Reference power设定值 ± 1 ” ，
 ± 0.5 更好

若为 “+” ，说明参比池有问题，受污染或气泡；
若为 “-” ，说明样品池有问题，不干净或气泡，也可能是参比池受污染

样品池强力清洗：可用Decon 90浸泡

如浓度14%，温度60°C，时间10-60min

(也可用5% SDS代替)

(样品池耐碱，不耐强酸)

参比池：只能水洗！

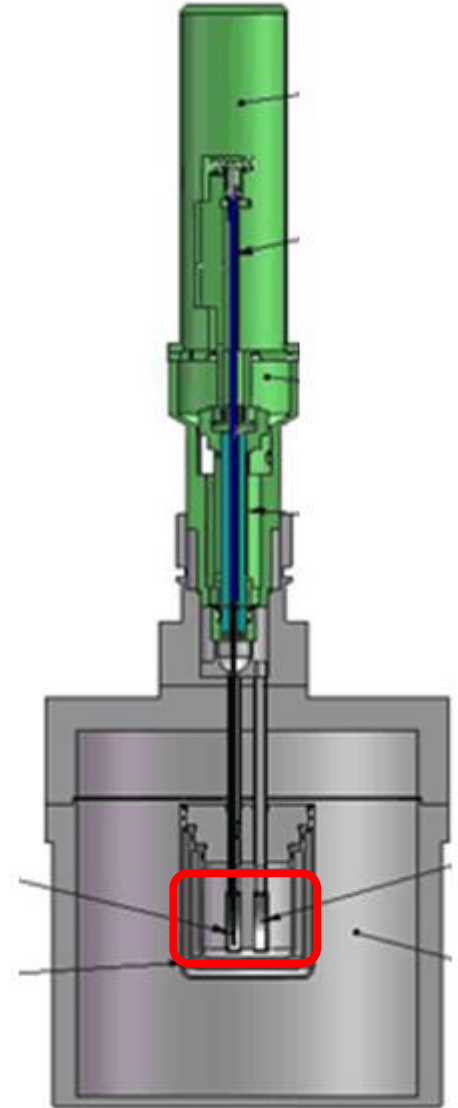



Good In - Good Out

怎么分析?



实验数据分析步骤

1. 导入数据并检查
2. 指定对照实验
3. 调整基线和积分范围 (可选操作)
4. 模型拟合
5. 导出最终结果

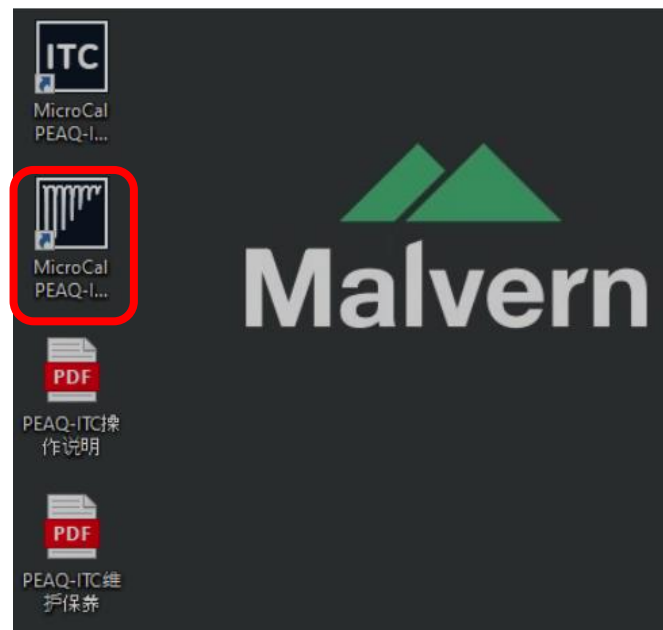

实验数据分析——导入数据与检查

Malvern MicroCal PEAQ-ITC Analysis Software

Analyze Experiment(s) Design Experiment

Start Analysis

Experiments Analyses

Browse... C:\ > Users > Public > Documents > Malvern Instruments > MicroCal PEAQ-ITC > Experiments > Installation20191105

Name	Modified Date
edta.itc	11/5/2019 4:10:05 PM
noise.itc	11/5/2019 1:44:57 PM
noise123.itc	11/5/2019 2:04:56 PM
water.itc	11/5/2019 2:44:35 PM

Open

Preview - edta.itc

Temperature (°C) 25.0
[Syr] (M) 1.00e-3
[Cell] (M) 100e-6
Reference Power (μcal/s) 10.0 (9.89)
Comment

DP (μcal/s)

Time (min)

实验数据分析——可添加多个数据



实验数据分析——指定对照实验

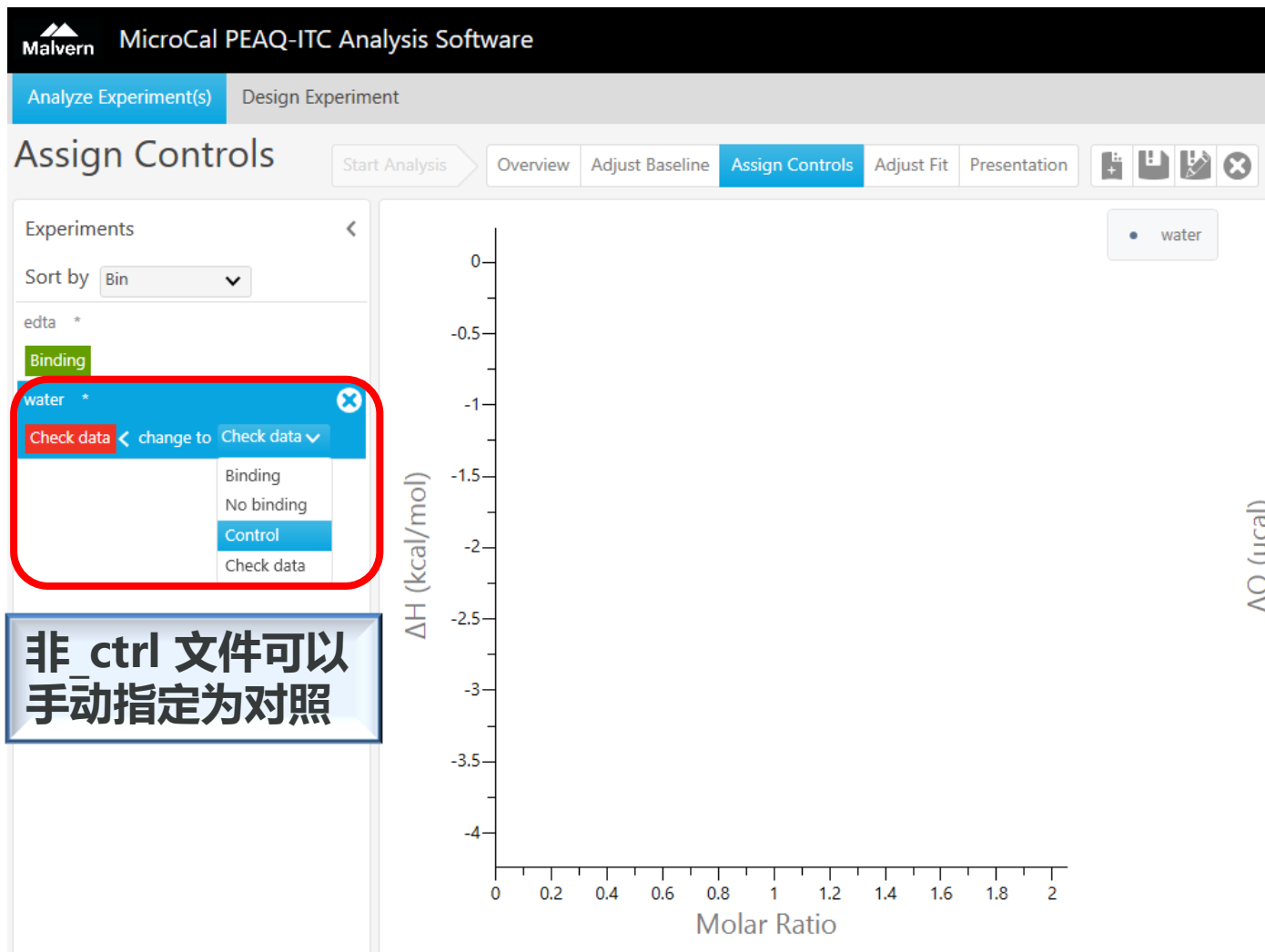

实验数据分析——指定对照实验

New Analysis - MicroCal PEAQ-ITC Analysis Software

Malvern MicroCal PEAQ-ITC Analysis Software

Analyze Experiment(s) Design Experiment

Assign Controls

Start Analysis Overview Adjust Baseline **Assign Controls** Adjust Fit Presentation

Experiments

Sort by Bin

CaEDTAgGetStart *
Binding >

CaEDTAgGetStart_ctrl *
Control

Control Parameters

Type Single

扣除对照的类型

Titrant -> Buffer (-) CaEDTAgGetStart_ctrl Method Line

对照指定与扣除方法

Reset Show Excluded Injections Show Legends

Experiment Information

Filename	CaEDTAgGetStart
Temperature (°C)	25.0
[Syr] (M)	1.00e-3
[Cell] (M)	100e-6
Ref. Power (μcal/s)	5.00 (5.35)
Comment	
Control Type	Single
Control Experiment	CaEDTAgGetStart_ctrl
Results	
Bin Comment	Binding
Competitive Model	No
[Syr] (M)	1.00e-3
[Cell] (M)	100e-6
Ligand In Cell	No
N (sites)	0.969 ± 1.5e-3



实验数据分析——调整基线和积分范围

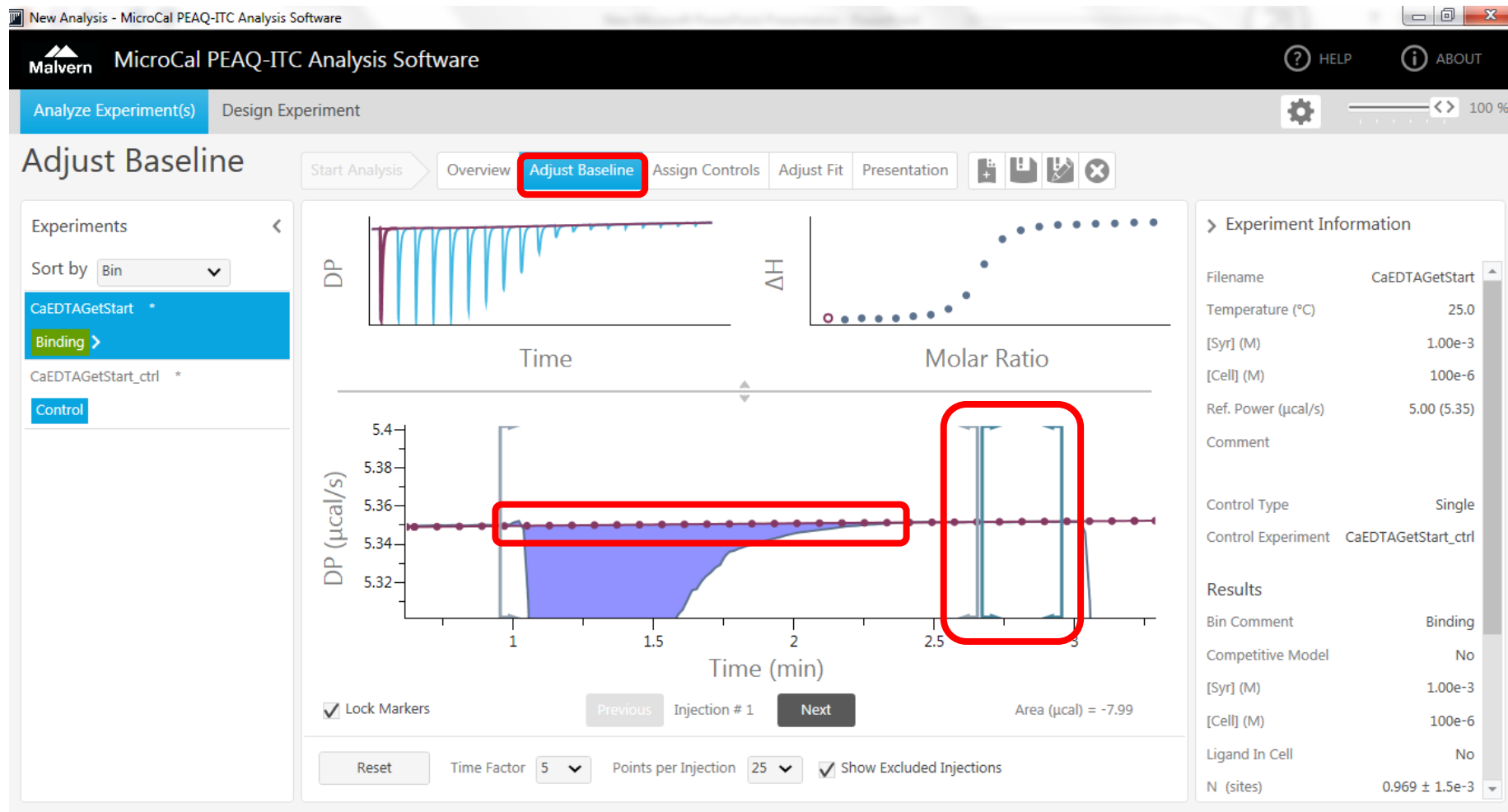

实验数据分析——模型拟合

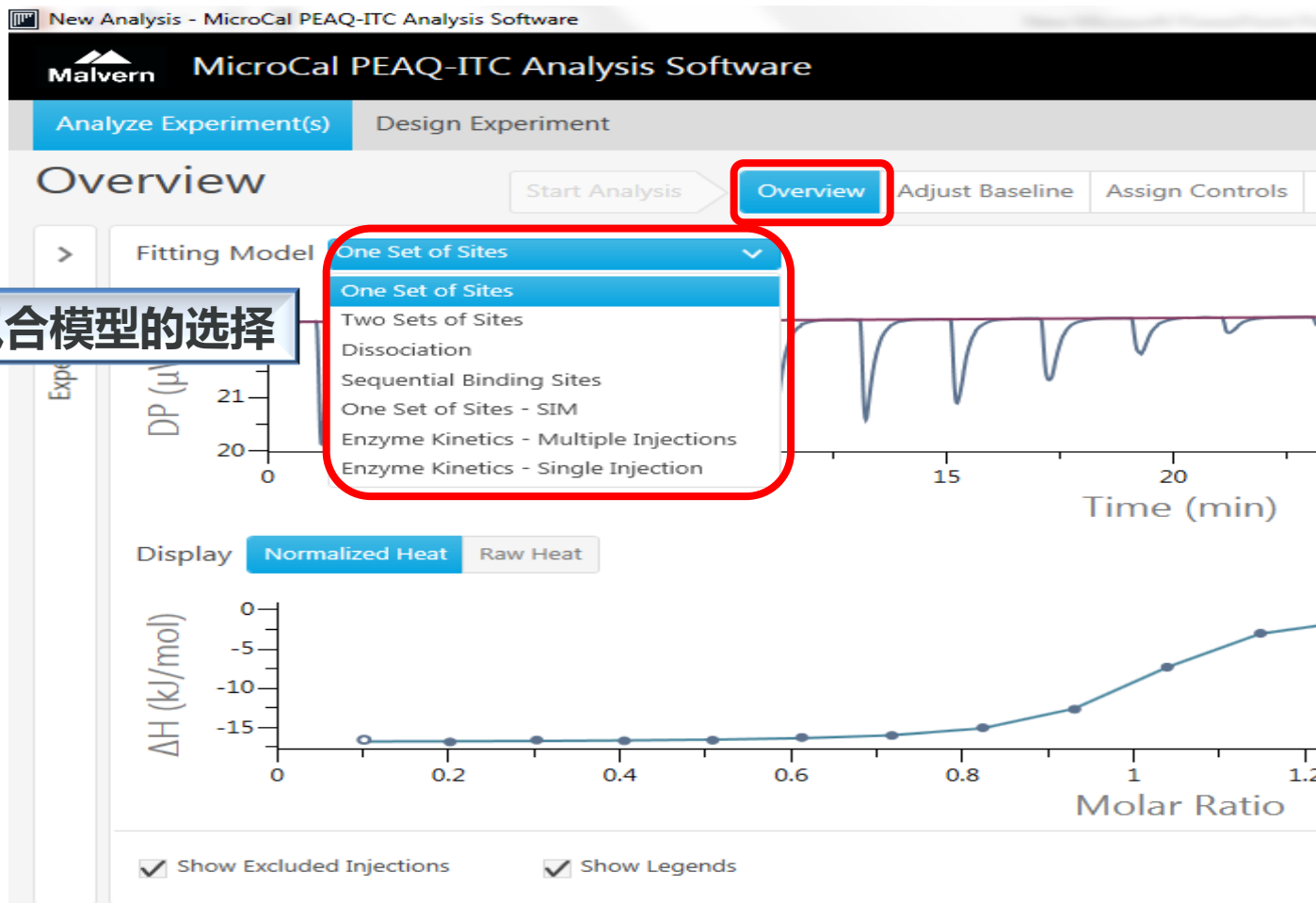

实验数据分析——模型拟合

New Analysis - MicroCal PEAQ-ITC Analysis Software

Malvern MicroCal PEAQ-ITC Analysis Software

Analyze Experiment(s) Design Experiment

Adjust Fit

Start Analysis Overview Adjust Baseline Assign Controls **Adjust Fit** Presentation

Experiments

Sort by Bin

CaEDTAGetStart *
Binding >
CaEDTAGetStart_ctrl *
Control



CaEDTAGetStart

Experiment Information

Filename: CaEDTAGetStart
Temperature (°C): 25.0
[Syr] (M): 1.00e-3
[Cell] (M): 100e-6
Ref. Power (μcal/s): 5.00 (5.35)
Comment:

Control Type: Single
Control Experiment: CaEDTAGetStart_ctrl

Results

Bin Comment: Binding
Competitive Model: No
[Syr] (M): 1.00e-3
[Cell] (M): 100e-6
Ligand In Cell: No
N (sites): 0.969 ± 1.5e-3

Fitting Parameters

Ligand is in Cell

Parameter	Vary	Initial Value	Lower Bound	Upper Bound
N (sites)	<input checked="" type="checkbox"/>	0.969	1.0e-3	10.0
Offset (kcal/mol)	<input type="checkbox"/>	0	-80.0	80.0
[Syr] (M)	<input type="checkbox"/>	1.00e-3	0	1.00

Use Competitive Model

Unknown Binder: Strong

[Weak] (M): 100e-6

Known Weak Parameters: Enter Manually

N (sites): 1.00

K_D (M): 1.00e-6

Reset Initialize Fit **Fit** Iterate Once Simplex Fit Show Excluded Injections Show Legend

拟合参数的修改



实验数据分析——导出最终结果

New Analysis - MicroCal PEAQ-ITC Analysis Software

Malvern MicroCal PEAQ-ITC Analysis Software

Analyze Experiment(s) Design Experiment

Presentation

Start Analysis Overview Adjust Baseline Assign Controls Adjust Fit Presentation

Result Table Final Figure Scatter Plot Injection Table Statistics Plot Signature Plot Raw Plot Integrated Heat Plot

Experiments

Sort by Bin

edta

Binding

water

Control

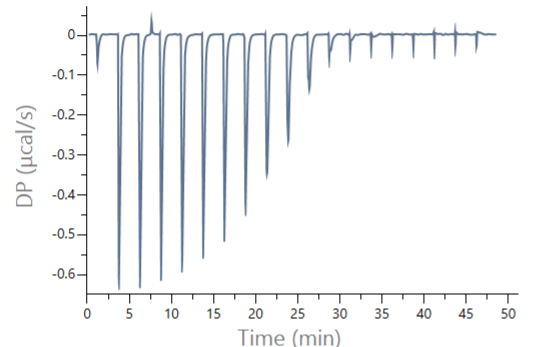

DP ($\mu\text{cal/s}$)

Time (min)

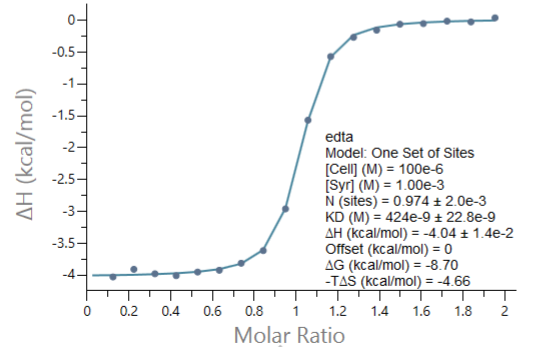

ΔH (kcal/mol)

Molar Ratio

edta
Model: One Set of Sites
[Cell] (M) = $1.00\text{e-}6$
[Syr] (M) = $1.00\text{e-}3$
N (sites) = $0.974 \pm 2.0\text{e-}3$
KD (M) = $424\text{e-}9 \pm 22.8\text{e-}9$
 ΔH (kcal/mol) = $-4.04 \pm 1.4\text{e-}2$
Offset (kcal/mol) = 0
 ΔG (kcal/mol) = -8.70
 $-\Delta\Delta S$ (kcal/mol) = -4.66

Show Results Subtract Baseline Subtract Offset

Export Data Export Image Chart Options Reset

输出的选项





常见问题



A to B 还是 B to A?

主要取决于样品浓度、溶解度、样品量、价格，以及是否有特别实验设计

29.5 μ M Protein titrated with
1.1mM Compound

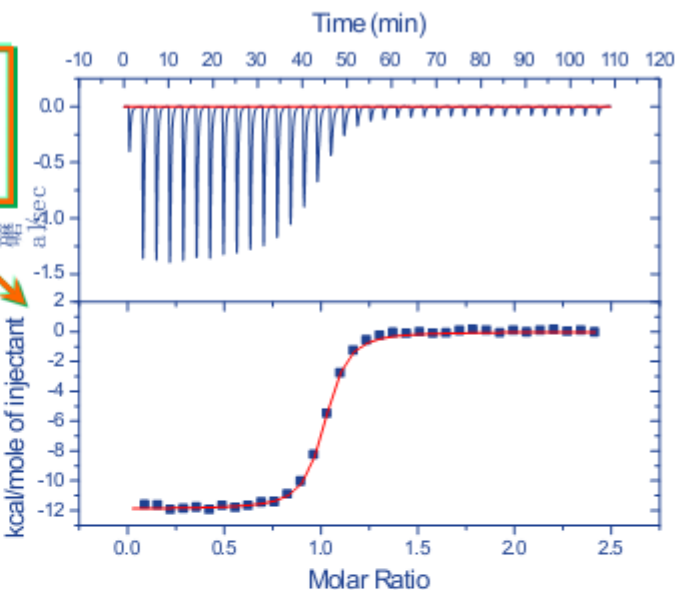

11.5 μ M Compound titrated with
179 μ M Protein

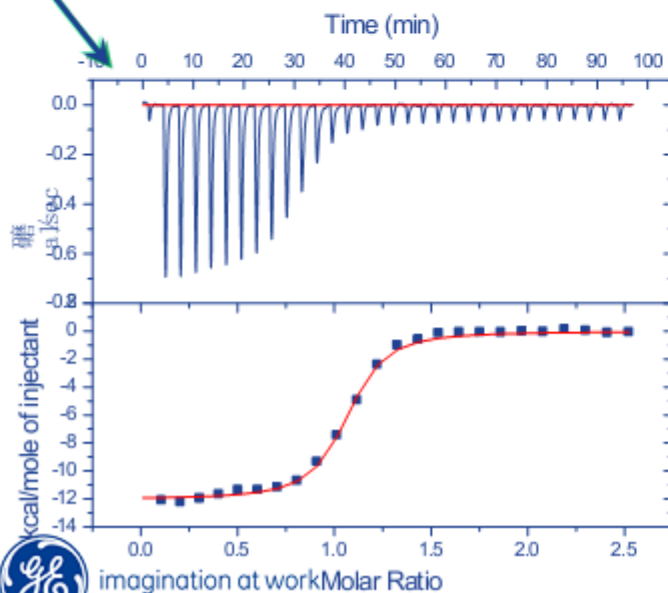

Parameter	Ligand in syringe	Ligand in cell
n	0.99	0.97
K_d	104 nM	105 nM
ΔG°	-9.4 kcal/mol	-9.4 kcal/mol
ΔH°	-11.9 kcal/mol	-12.4 kcal/mol
$T\Delta S^\circ$	-2.5 kcal/mol	-3.0 kcal/mol



N值不是0.5的倍数?

通常是蛋白质质量问题，或定量不准

Peptide binding to Batch 1 Protein

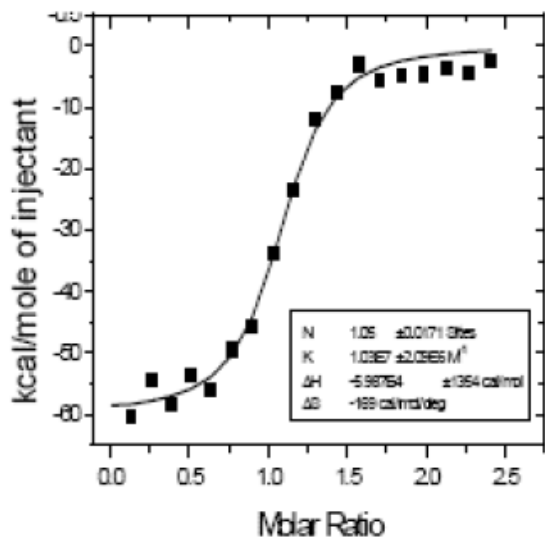

N = 1.05
K_D = 97 nM

100% of Batch 1
protein Active based
on Stoichiometry

Peptide binding to Batch 2 Protein

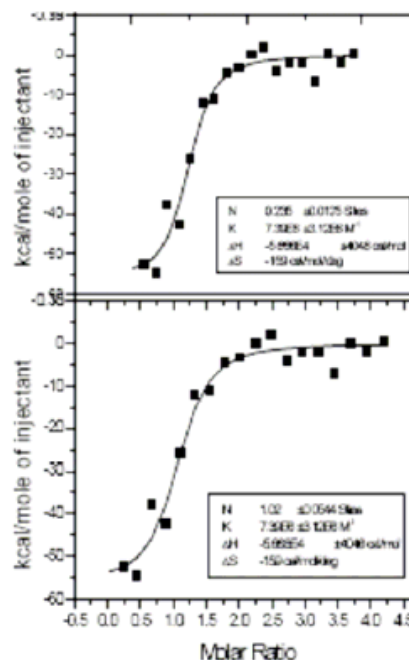

50 μM Peptide
10 μM Protein X

N = 0.235
K_D = 135 nM

Re-analyzed as
2.3 μM Protein X

N = 1.02
K_D = 135 nM

23% of Batch 2
protein Active based
on Stoichiometry



图不好看?

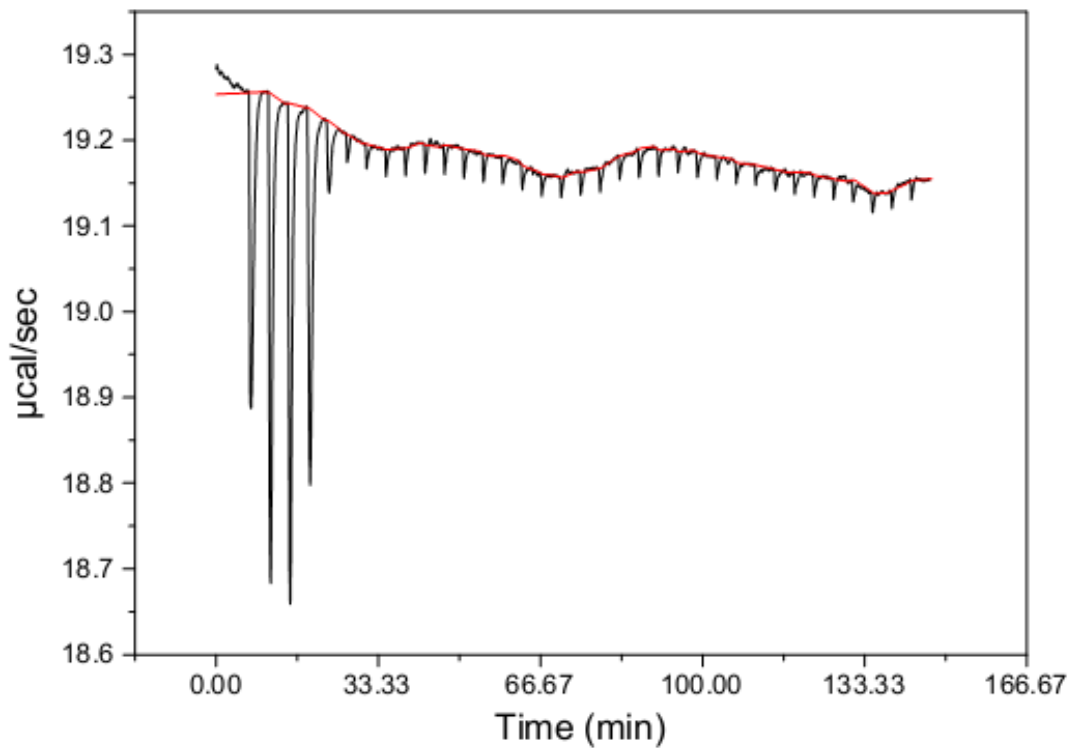

需调整浓度, 比如上图, 应该增加样品池浓度





异常峰

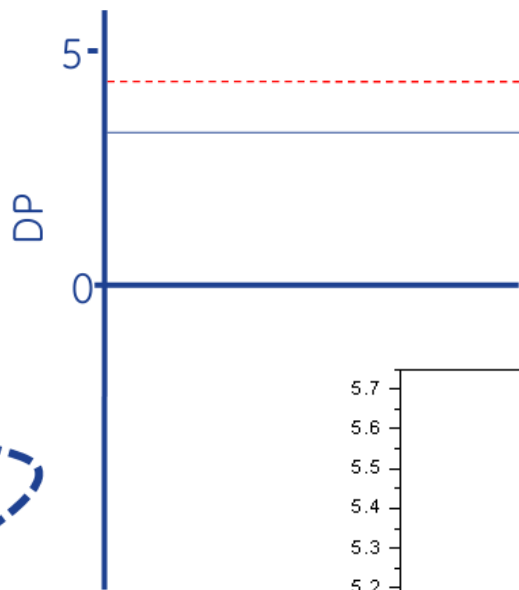
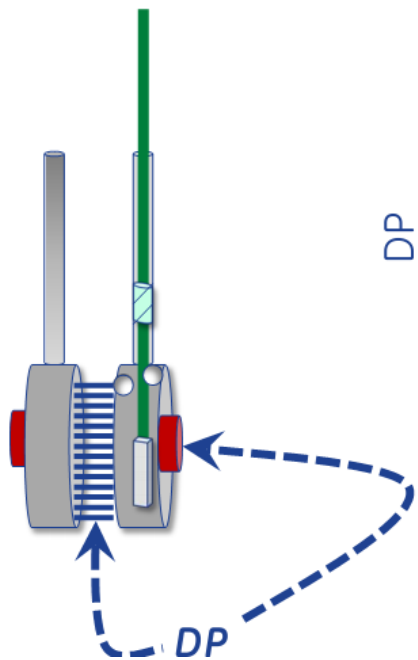

往往是气泡，或沉淀（颗粒）所导致

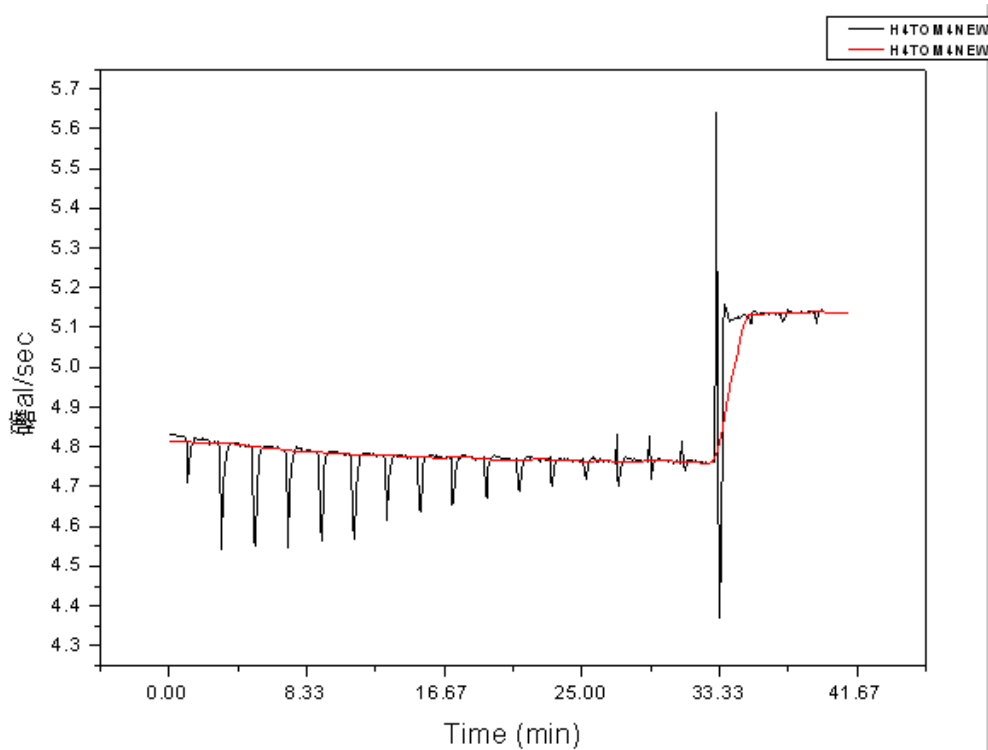



热量回不到基线

间隔时间不够

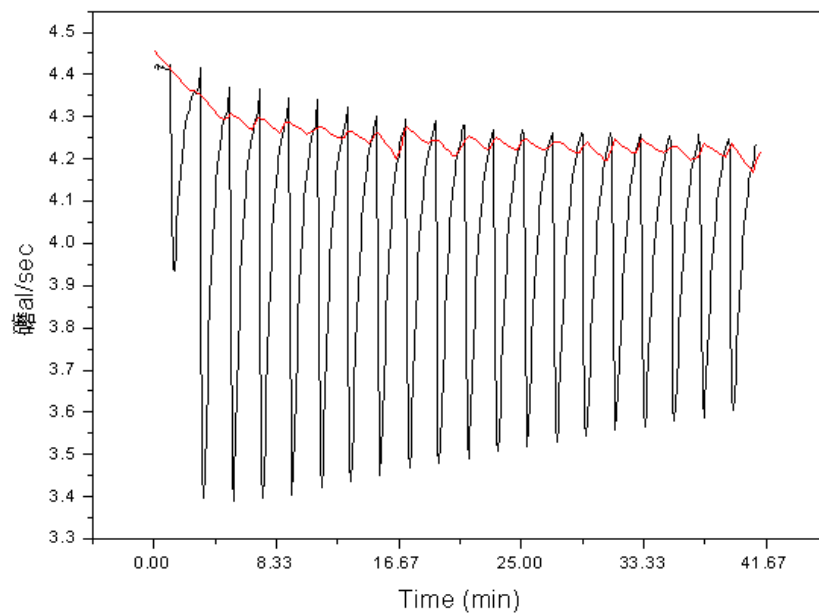
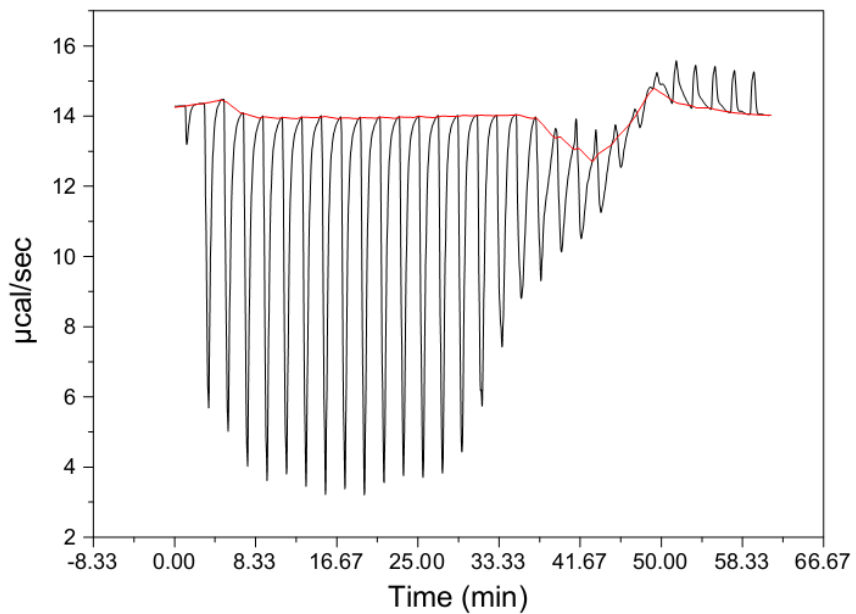
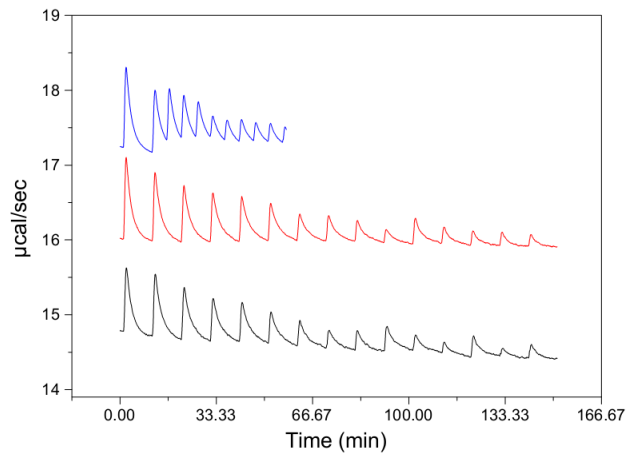



小结1 - 常见问题原因

- 没有结合/热量太小（浓度太低）
- 浓度比不合适
- Buffer不匹配
- 样品池不干净、上样未满、有气泡
- 参比池污染
- 间隔时间不够
- 蛋白聚集/沉淀
- Reference power太低或太高
- 仪器滴定针问题（弯曲、磨损、滑出等）





小结2 - 获取高质量数据的关键步骤

1. 实验设计合理，样品浓度合适
2. 好的样品准备
3. 准确的浓度测定
4. 实验操作：彻底清洗样品池和滴定针，水滴水确认仪器状态与洁净度，合理的滴定参数
5. 合适的空白对照
6. 合理的数据分析





更多内容我们在实验操作时进行交流

谢谢!

